

4000 Nanotechnology
Certified Under Counter
Filtration System

How to install, operate and maintain your
Microbiological Drinking Water Purifier



System tested and certified to meet the requirements of NSF Protocol P231 and NSF/ANSI Standards 42 & 53. See performance data sheet for details.

Manufactured by B. David Company
9333 Sheridan Avenue South * Bloomington, MN 55431
(952) 884-8417 * Info@bdavidwater.com
www.bdavidwater.com

Rev: 02/02/2017



Installation and Operation Manual

TABLE OF CONTENTS

	Page
What the Microbiological Drinking Water Purifier Will Do	3
Before You Start	3
Precautions	3
Specifications & Dimensions	3
Parts of the System.	4
Materials & Tools Needed	4
Installation Instructions	4-6
Step 1 – Installing the Saddle Valve	4
Step 2 – Selecting the Faucet Location	5
Step 3 – Mounting the Faucet	5
Step 4 – Mounting the System	5
Step 5 – Connecting the Faucet	5
Step 6 – Attaching Tube	6
Step 7 - Connecting the Saddle Valve	6
Step 8 – Connecting the Inlet Line to System	6
Step 9 – Setting the Effective Life Indicator	6
Step 10 – Putting the System into Operation	6
Filter Cartridges	7
Filter Cartridge Life	7
Filter Cartridge Replacement	7
Troubleshooting the System	8
Parts List	8
Exploded View & Parts List	9

WARRANTY

ONE YEAR LIMITED WARRANTY ON MICROBIOLOGICAL DRINKING WATER PURIFIER

Warrantor: B. David Company, 9333 Sheridan Ave. S., Bloomington, MN 55431

B. David Company warrants to the original owner (under normal use): all products and parts to be free from defects in material and workmanship for a period of one (1) year from the date of purchase. Any replacement products furnished will be free from defects in material and/or workmanship for the remainder of the original warranty period or 30 days, whichever is longer. This warranty does not cover: (1) defects not reported within the above time period, (2) problems arising from failure to comply with B. David Company instructions, (3) problems and/or damage arising from acts of nature, abuse, misuse, negligence or accident by any party other than B. David Company, (4) problems and/or damage resulting in whole or in part from alteration, modification, repair or attempted alteration, modification or repair by any party other than B. David Company, (5) noncompliance with applicable codes/ordinances.

If a defect in workmanship and/or material in a product or part covered by the warranty should arise, B. David Company, at its sole discretion, will repair or replace the defective product or part (B. David Company will consider the customer's preference in good faith).

All claimed defective product must: (1) be authorized for return by B. David Company with an RGA number (2) include proof of the purchase date of the product or part (3) returned to B. David Company prior to the expiration of the warranty date at the customer's expense, shipment pre-paid (4) be accompanied by a letter detailing the Model Number, Serial Number (if any), and a brief description of the problem.

TO THE MAXIMUM EXTENT PERMITTED BY APPLICABLE LAW, B. DAVID COMPANY DISCLAIMS ALL OTHER WARRANTIES, WHETHER EXPRESS OR IMPLIED, INCLUDING, BUT NOT LIMITED TO THE IMPLIED WARRANTY OF MERCHANTABILITY AND FITNESS FOR A PARTICULAR PURPOSE, WITH REGARD TO THE PRODUCTS, PARTS AND ANY ACCOMPANYING WRITTEN MATERIALS.

To the maximum extent permitted by applicable law, B. David Company shall not be liable for any damages whatsoever (including, but not limited to, loss of time, inconvenience, expenses, labor or material charges incurred in connection with the removal or replacement of the products or parts, special, incidental, consequential, or indirect damages for personal injury, loss of business profits, business interruption, loss of business information, or any other pecuniary loss) arising out of the use of or inability to use the defective products or parts even if B. David Company has been advised of the possibility of such damages.

The B. David Company maximum liability under any provision of this Limited Warranty shall be limited to the amount actually paid for the products or parts.

This warranty is effective if the Microbiological Drinking Water Purifier is operated at water pressured between 30-100 psig and a water temperature between 40-100°F. Furthermore, the purifier must not be subject to mistreatment, system modification, disregard, freezing, carelessness, or damage as a result of any unusual force of nature (i.e. hurricane, flood, earthquake, or tornado). Warrantor is excused if failure to perform its warranty obligations is the result of material shortages, government regulation, strikes, or any other circumstances beyond its control.

What the Drinking Water Purifier Will Do

The 4000 Nanotechnology Certified Under Counter Filtration System is a water purification treatment system. This system uses a triple filter design to reduce unwanted elements in your drinking water. Possible elements may include chlorine, lead, virus, bacteria, cysts, particulates and numerous organic compounds.

The 4000 Nanotechnology Certified Under Counter Filtration System utilizes the patented Nano and other technologies in a systematic approach to ensure the water supply conforms to EPA Guide Standard for the removal of 99.9999% Bacteria, 99.99% Viruses, and 99.95% Cysts. The 4000 Nanotechnology Certified Under Counter Filtration System is designed to discontinue water flow when its capability to filter unwanted elements has been exhausted. This will help safeguard the consumer against contaminated water. Replace all filters every 12 months or 1000 gallons.

NOTE: A performance data sheet is included and lists what elements will be reduced from the water supply. (Please note that not all elements may be present.) This data sheet lists the individual contaminants and microbial reduction performance.

The drinking water purifier system is designed to fit under the kitchen or bathroom sink or any other area that is suitable. A COLD water supply pipe is required within a few feet. If water supply pipe is farther than what the tube will reach, you can purchase longer lengths of tubing from your local home improvement center.

NOTE: Make sure the tubing is acceptable for use on potable water supplies.

Before You Start

- ❖ In order to receive all of the benefits of your microbiological drinking water purifier, be sure to read all steps in this guide carefully and follow steps exactly.
- ❖ **This system is intended for use with municipal and/or well-supplied water only. It is not intended for use with surface water such as from a lake or runoff.**
- ❖ **Do not use for the treatment of water that is visually contaminated (cloudy) or has an obvious contamination source, such as contamination by raw sewage.**
- ❖ **Systems certified for cyst reduction may be used on disinfected waters that may contain filterable cysts.**
- ❖ **System is not intended to convert wastewater or raw sewage into drinking water.**
- ❖ Installation and plumbing should comply with all local laws and regulations. Consult with your licensed plumber.
NOTE: In Massachusetts, plumbing code 248 CMR 3.00 and 10.00 shall be adhered to.
- ❖ The microbiological drinking water purifier works on water pressure of 30 psig (minimum) to 100 psig (maximum). If your house water pressure is over the maximum, install a pressure reducing valve in the water supply pipe to the filter system.
- ❖ Do not install the microbiological drinking water purifier outside, or in extreme hot or cold temperatures. Temperature of the water supply to the under-sink drinking water filter system must be between 40°F and 100°F. Do not install on hot water.
- ❖ Do not use with water that is microbiologically unsafe or of unknown quality without disinfection before or after the system.
- ❖ Systems certified for cyst reduction may be used on disinfected waters that may contain filterable cysts.

Precautions

- This system is for “cold water” use only.
- Protect filters against freezing, which can cause cracking of the filter and water leakage.
- The rubber O-ring provides the water-tight seal between the cap and the bottom of the housing. It is important that the O-ring be properly seated in the groove below the threads of the housing or a water leak could occur.
- To prevent costly repairs or possible water damage, the sump of plastic housings must be replaced every ten years. If sump is older than recommended, replace immediately. Date sump for reference and indicate replacement date.

Specifications & Dimensions

Supply Water Pressure	30 – 100 psig
Min - Max	(2.1-6.7 bar)
Supply Water Temperature	40 - 100°F
Min. – Max.	(4.4 – 37.8°C)
Service Flow Rate	
@60 psig	(0.5 GPM @4.1 bar)
Rated Service Life	1000 gallons (3,785 L)
Dimensions	15.5” H x 5.25” D x 14” L
	(394mm x 133mm x 356mm)
Weight	(filled with water) 19lbs (8.6kg)



Parts of the System

- Filter system with filter cartridges
- Installation hardware (mounting screws, saddle valve, flow restrictor, fittings)
- 1/4-inch (6.35mm) tubing
- Lead-free faucet

Materials and Tools Needed

Note: Gather the required tools before starting installation. Read and follow the instructions provided with any tools listed here.

- Safety glasses
- Hand or electric drill (cordless recommended)
- File or sandpaper
- Phillips Head screwdriver
- 2 adjustable wrenches
- Tube cutters or utility knife

****If sink does not have hole for separate faucet:**

- Center punch
- 3/4-inch (19mm) drill bit
- Masking tape

IMPORTANT: To avoid damaging the sink, consult a qualified plumber or installer for drilling procedures in porcelain, granite, or stainless steel.

Installation Instructions

NOTE: A squeaking sound when tightening a compression nut is normal.

NOTE: If fittings are removed, Teflon® tape must be used for pipe threaded connections.

NOTE: Be sure to wear safety glasses when using a drill.

- System is designed for standard under-sink installation on 3/8"-inch (10mm) cold water line.
- Numbered diagrams correspond with numbered steps.

Step 1 – Installing the Saddle Valve

Use of a cordless drill is recommended. To protect yourself from serious injury or fatal shock when using an electric drill, be sure the drill and the outlet it is plugged into are properly grounded. When using a drill, follow the manufacturer's guidelines and procedures.

NOTE: Saddle valve must be installed on a 2-inch (51mm) long, straight-walled section of 3/8-inch to 7/8-inch (10-22mm) steel, brass, copper, or PVC pipe

- Turn off cold water supply and turn on nearest faucet before starting installation. Place a tray or towels under the cold water line to catch excess water.
- Drill a 1/8-inch (3mm) hole in the cold water line. Remove any burrs with sandpaper or file.
- Turn handle on the saddle valve to expose lance no more than 3/16-inch (5mm) above black rubber gasket.
- Place valve body over hole in cold water line so lance fits into hole.
- Attach back plate of clamp and tighten bolts evenly and firmly so brackets are parallel.
- Turn valve handle clockwise to closed position and leave closed until installation is complete.

NOTE: All nuts must be retightened when the system reaches projected operating temperature.

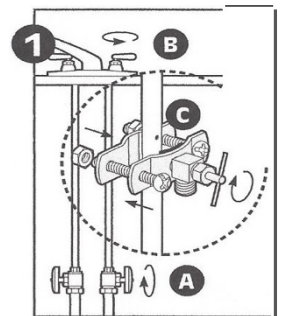

Installation Instructions

Step 2 – Selecting the Faucet Location

NOTE: The drinking water faucet should be positioned with function, convenience, and appearance in mind. An adequate flat area is required to allow faucet base to rest securely. The faucet fits through a 3/4-inch (19mm) hole. Most sinks have pre-drilled 1-inch (35 or 38mm) diameter holes that may be used for faucet.

- Line bottom of sink with newspaper to prevent metal shavings, parts, or tools from falling down drain.
 - Place masking tape over the area to be drilled to prevent scratches if drill bit slips.
- IMPORTANT: To avoid damaging the sink, consult a qualified plumber or installer for drilling procedures in porcelain, granite, or stainless steel.**
- Mark hole with center punch. Use a 1/4-inch (6mm) drill bit for a pilot hole, then, using a 3/4-inch (13mm) drill bit or hole saw, drill a hole completely through the sink. Smooth rough edges with a file.

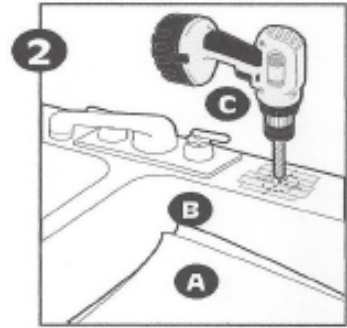

Step 3 – Mounting the Faucet

- Remove wing nut (C) and metal washer (B) from the threaded shaft of the faucet. Leave the black rubber washer (A) on the threaded shaft.
- Slide the threaded shaft of the faucet into drilled hole.
- From under the sink, slide the metal washer on and thread on the wing nut. Tighten wing nut by hand until tight. It may be necessary to have a second person hold the faucet while tightening the wing nut.
- Install the faucet spout into the base by pushing firmly into hole in base then screw cover hand tight.

Caution: Do not over-tighten the wing nut. Hand tighten only. Do not use pliers or wrench to tighten.

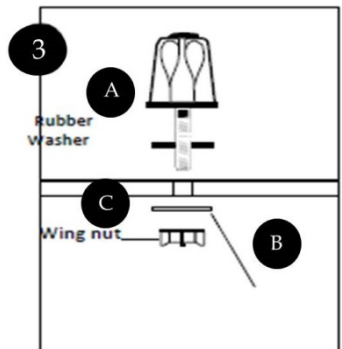

Step 4 – Mounting the system

- Center system between water supply adapter and drinking water faucet. NOTE: Allow 1.5 inches (38mm) clearance below system to enable filter cartridge changes.

NOTE: In the following step, leave enough space (approximately 1/2-inch (13mm)) between the head of the screw and the wall to easily slip system into place.

- Install mounting screws at least 15-inches (380mm) from cabinet floor and 9 1/4-inches (235mm) apart. Place system over screws on wall and slide sideways. Tighten screws.

Caution: Make certain system is firmly attached to wall to prevent possible damage from falling.

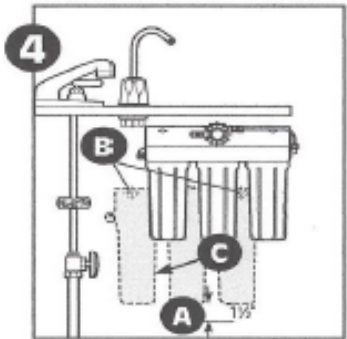

Step 5 – Connecting Tubing to the Faucet

Caution: Do not over-tighten compression nut. Use caution not to bend or crimp tubes when securing.

- Locate compression nut in installation kit and faucet package.
- Attach compression nut pieces (3) to one end of tubing. **Caution: Tube must be fully inserted in the compression fitting base to the tube stop on the faucet stem.**
- Attach tube with compression nut assembly to faucet stem by inserting tube into the faucet stem opening. Gently push the tubing until it comes to a stop.

NOTE: All nuts must be retightened when the system reaches projected operating temperature.

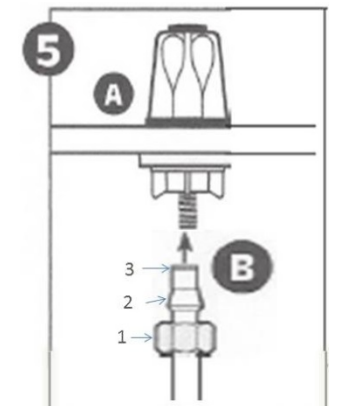

Installation Instructions

Step 6 – Attaching Tube to Effective Life Indicator (ELI)

- Determine the length of tubing needed from the faucet to the ELI. A slight sag in the line will allow for some ease in installation. Cut the tubing to required length.
- Insert other end of tubing firmly into the outlet port (John Guest® fitting) of the ELI until fully engaged.
- Pull tube gently to ensure the tubing is fully seated.

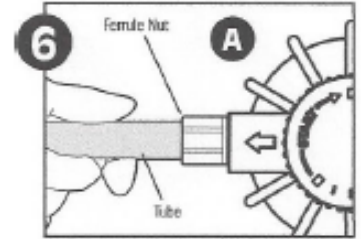

Caution: Tube must be fully inserted in the compression fitting base on the outlet stem of the ELI.

Step 7 – Connecting the Saddle Valve

- Determine the length of plastic tubing needed to connect the inlet (left) side of the filter with the saddle valve. Be sure to allow enough tubing to prevent kinking and cut the tubing squarely. Slide brass compression nut onto tubing, followed by plastic ferrule. The long tapered end of the ferrule should face towards the end of the tubing. Place insert into tubing.
- Insert tubing into saddle valve and hand-tighten compression nut. Using a wrench, tighten nut 1 to 1 ½ turns.

NOTE: All nuts must be retightened when the system reaches projected operating temperature.

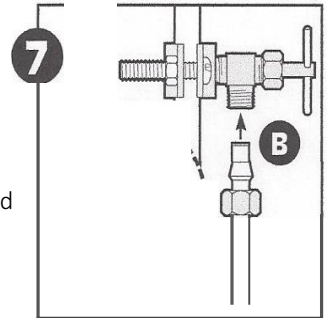

Step 8 – Connecting Inlet Line to System

- Insert other end of tubing firmly into inlet port (John Guest® fitting) until fully engaged.
- Pull tube gently to ensure the tubing is fully seated.

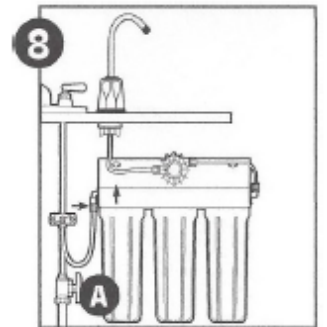

Step 9 – Setting the Effective Life Indicator

NOTE: The effective life indicator is the white dial located on the center of the mounting bracket. Each black mark on the dial represents 100 gallons (378.5 L).

- Move the dial clockwise so that the black indicator arrow lines up with the 1100 gallon (4,164 L) mark.

Important: Set flow meter to 1100 gallons after each new filter replacement.

NOTE: To prevent indicator malfunctions, only move the dial when the system is depressurized.

NOTE: Based on the settings sensitivity of the Effective Life Indicator (ELI), user should set the ELI to 1,100 gallons to assure a 1,000 gallon cycle.

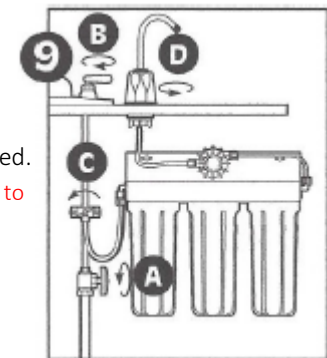

Step 10 – Putting the System into Operation

- Slowly turn on cold water supply.
- Rotate handle on base of drinking water faucet counter-clockwise to "ON" position. Allow water to run for 10 minutes to flush air and carbon fines from filter cartridges. Check system for leaks before completing installation.
- Make sure that all nuts are tightened.

NOTE: A drinking water cartridge may contain carbon fines (very fine black powder). It is recommended that you run the tap at least 20 seconds prior to using water for drinking or cooking purposes.

NOTE: Initially, filtered water may appear cloudy. If you set a glass of water on a level surface, you should be able to watch the cloudiness disappear from the bottom of the glass upwards. This harmless cloudiness results from the release of trapped air with the cartridge and will disappear within a few weeks after installation.

INSTALLATION IS NOW COMPLETE.

Filter Cartridges

Filter Cartridge Life

It is recommended to **replace filter cartridges every 12 months or 1,000 gallons** of use. However, your water quality can lead to circumstances such as diminished water flow, visible sediment, or unwanted taste and/or odor in your water, requiring the cartridges be replaced sooner.

NOTE: Based on the settings sensitivity of the Effective Life Indicator (ELI), user should set the ELI to 1,100 gallons to assure a 1,000 gallon cycle.

There are several variables that determine how long a cartridge will last. These include:

1. How much water you use, and
2. How much sediment, chlorine, or other unwanted substances is in the water.

Filter Cartridge Replacement

NOTE: Contact your system supplier for replacement filter parts.

1. Turn off cold water supply to system and turn on faucet to release pressure.
NOTE: Due to water leakage, place pan or towel under sump.
2. Unscrew and remove bottom of filter housing. Locate and remove large O-ring, wipe clean of lubricant, and set aside. Repeat for second and third housings.
3. Discard used filter cartridges.
Caution: Read "WARNING" information on the bleach container before using.
4. Using a non-abrasive sponge or cloth, scrub the bottom of each housing, O-ring grooves, and caps with dish soap and warm water. Rinse thoroughly. Then fill bottom of each housing 1/3 full with water. Add 1TBSP (14.7ML) of household bleach and scrub to disinfect.
5. Lubricate O-rings with clean silicone grease. Insert each O-ring in groove and press into place.
NOTE: This step is important to ensure a proper housing seal. Make certain each O-ring is seated level in its groove or a leak may occur.
6. Screw bottom of housing(s) with bleach water onto cap(s) without filter cartridge(s) and hand-tighten. **DO NOT OVER-TIGHTEN.**
7. Turn on water supply. Let faucet run for about 10 seconds, then turn off faucet and let stand for 20-30 minutes.
8. Turn on faucet and allow bleach water to run out (about 3-5 minutes)
9. Turn off water supply to system. Remove bottom of housings and empty out water.
10. Insert each filter cartridge in bottom of appropriate filter housing.
IMPORTANT: Be sure to remove any protective covering from the filters before inserting.
11. Screw bottom of housing(s) onto cap(s) and hand-tighten. **DO NOT OVER-TIGHTEN.** Make certain cap standpipe slips into cartridge(s).
12. Reset effective life indicator to 1,100 gallons (see instruction under "Setting Effective Life Indicator" on Page 6.)
13. Turn on water to system. Let faucet run for 10 minutes to remove trapped air and carbon fines. Check system for leaks.

REPLACEMENT FILTERS (4010 3-Pack)

4001 First Stage Nano Filter

4002 Second Stage FI Filter

4003 Third Stage DE Block

Troubleshooting the System

Problem: Leaks between cap and bottom of filter housing	Correction: Turn off water supply and turn on drinking water faucet to release pressure in system. Remove bottom of housing. Clean O-ring groove (located directly beneath threads of housing). Lubricate O-ring with silicone grease and replace securely into groove. Screw bottom of housing onto cap and hand-tighten. DO NOT OVER-TIGHTEN. Turn on water supply and check for leaks
Problem: Leaks on system inlet/outlet connections	Correction: Turn off water supply and turn on drinking water faucet to release pressure in system. Remove tubing from fitting and make sure end of tubing is cut squarely and free of burrs. Reinsert tubing into fitting, making sure to push tubing to a hard stop. Hand-tighten compression nut first, then tighten 1 to 1 1/2 turns for new compression nut. Tighten only 1/2 to 1 turn with wrench for previously tightened compression nut. NOTE: If leaks persist, or if there are other leaks in system, turn off water supply.
Problem: Leaks on faucet / tubing connection	Correction: Turn off water supply and turn on drinking water faucet to release pressure in system. Loosen and remove compression nut fitting on faucet stem. Make sure tubing is inserted firmly into end of faucet stem, then retighten compression nut with fingers until secure. Turn on saddle valve, and then turn off faucet to check for leaks. NOTE: If leaks persist, or if there are other leaks in system, turn off water supply.
Problem: No water or decreased water flow.	Correction: Check flow at faucet. The 4000 Nanotechnology Certified Under Counter Filtration System system should fill a gallon jug in approximately 2 minutes. Flow rates will vary with individual household water pressure. Correction: Check filter cartridge installation. Make certain all filter cartridges are properly oriented in filter housings. Correction: Replace filter cartridges.

Parts List

ITEM#	QTY	PART#	DESCRIPTION
1	1	4002991	MTG BRACKET, 3 HOUSING WHITE
	1	144169-02	MTG BRACKET, 3 HOUSING WHITE (ALTERNATIVE)
2	2	SH244788	ELBOW, 1/4" NPT X 1/4" QC WH PP
3	2	SH244791	NIPPLE, MALE HEX 1/4" NPT X 1/4" NPT
4	3	158125	1/4" #10 SL WHITE WO/PR 12/C
5	4	SH143263	SCREW #6X 1/4" LG PHIL PAN
6	1	42561	LUBRICANT, SILICONE, PACKET
7	1	150539	WRENCH SW-1A
8	12	PW-80-09	SCREW, #10 - 32 X 3/4" PAN HEAD
9	1	4002987	VALVE, SADDLE 1/4 COMPRESSION
10	2	SH243249	SCREW #10-12 X 1.5 TYPE A
11	3	C143026	LOCAL "O-RING"
13	2	244960	DEFENG FAUCET, STANDARD
14	1	161127	METER, 1800 GALLON, 1/4 NPT

ITEM#	QTY	PART#	DESCRIPTION
15	1	4003	THIRD STAGE DE BLOCK
16	1	4002	SECOND STAGE FI FILTER
17	1	4001	FIRST STAGE NANO FILTER
20	2	161123	FILTER TIMER MONITOR, 12 MONTH
21	1	161125	INSTRUCTION SHEET, TIME STRIP
22	0.0240	SH144223	MACHINE TAPE, TEFLON 1/4" WIDE
	RL		
25	1	1611161	MANUAL, B. DAVID COMPANY 4000 NANOTECHNOLOGY CERTIFIED UNDER COUNTER FILTRATION SYSTEM
	10.000		
26	FT	SH243244	TUBE, 1/4" OD WHITE PE
27	2	161143	DM FITTING; 1/4" X 1/4" QC; NPT
24		N/A	
32	0.1250	SH243244	TUBE, 1/4" OD WHITE PE
	FT		
33	0.4583	SH243244	TUBE, 1/4" OD WHITE PE
	FT		
34	1	244985	INLINE FLOW RESTRICTOR, 0.5 GPM

EXPLODED PARTS VIEW

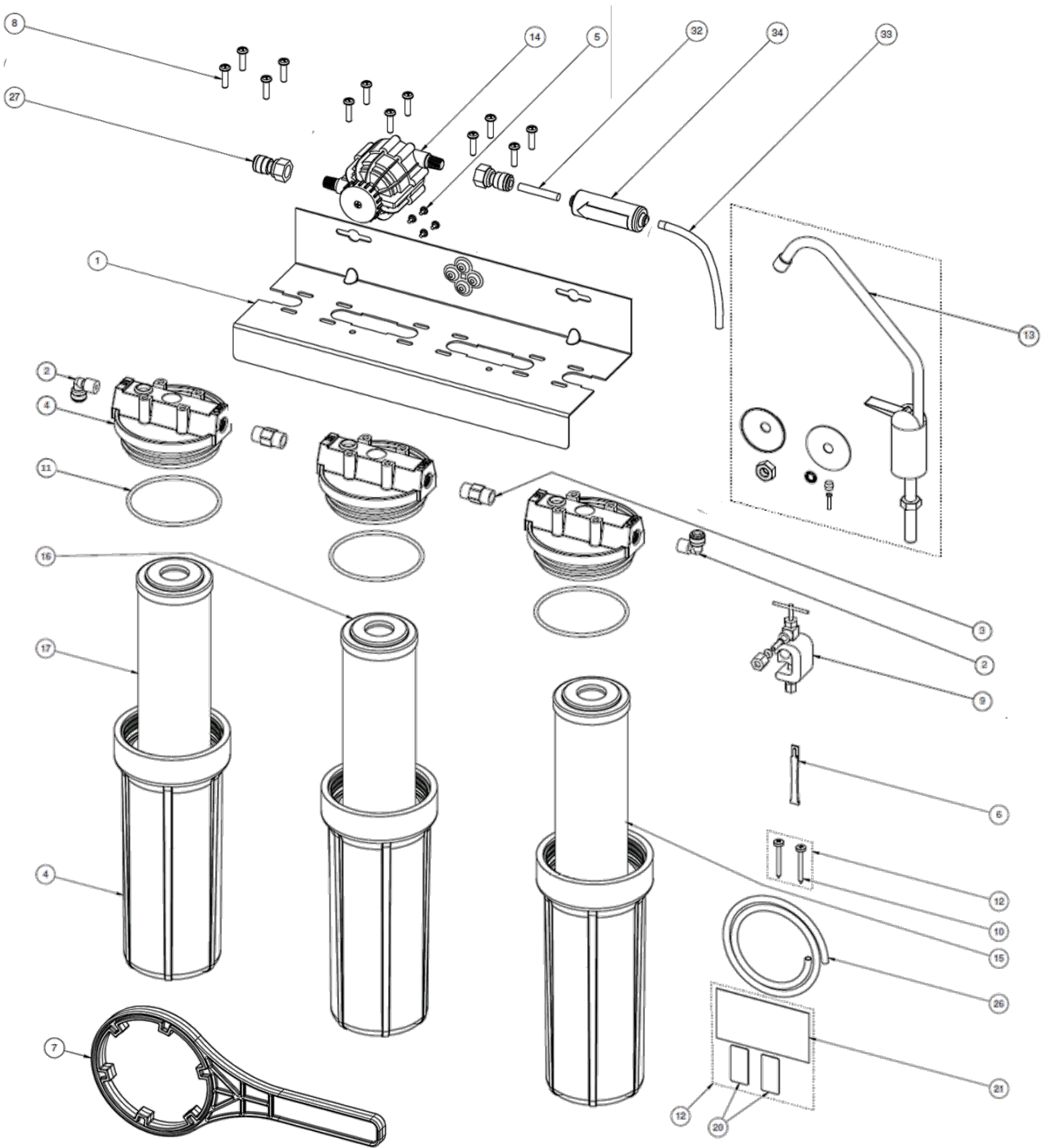

This Page Intentionally Left Blank

This Page Intentionally Left Blank